



مجلة التربوي
Journal of Educational
ISSN: 2011- 421X
Arcif Q3

معامل التأثير العربي 1.5
العدد 21



مجلة التربوي

مجلة علمية محكمة تصدر عن كلية التربية

جامعة المرقب

العدد الحادي والعشرون
يوليو 2022م

هيئة التحرير

رئيس هيئة التحرير: د. مصطفى المهدي القط
مدير التحرير: د. عطية رمضان الكيلاني
سكرتير المجلة: أ. سالم مصطفى الديب

- المجلة ترحب بما يرد عليها من أبحاث وعلى استعداد لنشرها بعد التحكيم .
 - المجلة تحترم كل الاحترام آراء المحكمين وتعمل بمقتضاها .
 - كافة الآراء والأفكار المنشورة تعبر عن آراء أصحابها ولا تتحمل المجلة تبعاتها .
 - يتحمل الباحث مسؤولية الأمانة العلمية وهو المسؤول عما ينشر له .
 - البحوث المقدمة للنشر لا ترد لأصحابها نشرت أو لم تنشر .
- (حقوق الطبع محفوظة للكلية)



ضوابط النشر:

- يشترط في البحوث العلمية المقدمة للنشر أن يراعى فيها ما يأتي :
- أصول البحث العلمي وقواعده .
 - ألا تكون المادة العلمية قد سبق نشرها أو كانت جزءا من رسالة علمية .
 - يرفق بالبحث تزكية لغوية وفق أنموذج معد .
 - تعدل البحوث المقبولة وتصحح وفق ما يراه المحكمون .
 - التزام الباحث بالضوابط التي وضعتها المجلة من عدد الصفحات ، ونوع الخط ورقمه ، والفترات الزمنية الممنوحة للتعديل ، وما يستجد من ضوابط تضعها المجلة مستقبلا .

تنبيهات :

- للمجلة الحق في تعديل البحث أو طلب تعديله أو رفضه .
- يخضع البحث في النشر لأولويات المجلة وسياستها .
- البحوث المنشورة تعبر عن وجهة نظر أصحابها ، ولا تعبر عن وجهة نظر المجلة .

Information for authors

- 1- Authors of the articles being accepted are required to respect the regulations and the rules of the scientific research.
- 2- The research articles or manuscripts should be original and have not been published previously. Materials that are currently being considered by another journal or is a part of scientific dissertation are requested not to be submitted.
- 3- The research articles should be approved by a linguistic reviewer.
- 4- All research articles in the journal undergo rigorous peer review based on initial editor screening.
- 5- All authors are requested to follow the regulations of publication in the template paper prepared by the editorial board of the journal.

Attention

- 1- The editor reserves the right to make any necessary changes in the papers, or request the author to do so, or reject the paper submitted.
- 2- The research articles undergo to the policy of the editorial board regarding the priority of publication.
- 3- The published articles represent only the authors' viewpoints.





The Use of Staggered Array of Aluminum Fins to Enhance the Rate of Heat Transfer While Subject To a Horizontal Flow

Mohsen Faroun Ahmed¹, Assma Musbah Said²
^{1,2} University of Zawia
²a.said@zu.edu.ly

Abstract

In order to experimentally measure the thermal performance of the finned heat sink, it is essential that the rate of heat transfer between the heat sink and the flowing water be accurately measured at horizontal positions to different types of fluid. The aim of this study is to experimentally investigate the fin heat transfer performance and pressure drop properties of an offset-strip fin at a various fin positions. In the present study, experiments are conducted at the range of Reynolds number from 2000 to 11000 for water system. The computations are conducted by assuming that the flow in the offset-strip fin channels is steady and turbulent at the range of Reynolds numbers from 4000 to 11000. In this paper, the effects of the water flow behaviors in the array of fin channels on fanning friction (f) factor, which is the non-dimensional form of pressure drop, is investigated. Also, the hydraulic diameter (Dh) and the volumetric flow rate of the water fluids are kept different for these fins in order to see the effect of those. The effect of Prandtl number is investigated by using water, $0.1 < Pr < 0.64$. According to obtained results, there is an effect of types of water flow for various flow rate to the fin heat transfer performance with constant hydraulic diameter (Dh). Also, the experimental results observed that the performance of heat transfer rate to laminar flow is better in respect of heat transfer coefficient, fin efficiency, thermal resistance, and fin effectiveness when compared to those of transition and turbulent water flow.

1.1 Introduction

A heat exchanger is a device which is used to transfer thermal energy between two or more fluid, between a solid surface and a fluid, or between solid particulates and a fluid, at different temperatures and in thermal contact. Extended surface heat transfer plays a very important role in heat exchangers involving water as one of the fluids. Heat exchangers often used in the process, power, petroleum, air-conditioning, refrigeration, cryogenic, heat recovery, alternative fuel, and manufacturing industries, they also serve as key components of many industrial products available in the market. The heat exchangers can be classified in several ways such as, according to the transfer



process, number of fluids and heat transfer mechanism. Heat exchangers, on the basis of constructional details, can be classified into tubular, plate-type, extended surface and regenerative type heat exchangers. The tubular and plate-type exchangers are the primarily used surface heat exchangers with effectiveness below 60% in most of the cases.

Plate fin type extended surface heat exchangers have corrugated fins mostly of triangular or rectangular cross-sections sandwiched between the parallel plates. These are widely used in automobile, aerospace, cryogenic and chemical industries, electric power plants, propulsive power plants, systems with thermodynamic cycles i.e. heat pump, refrigeration etc. and in electronic, gas-liquefaction, air-conditioning, waste heat recovery systems etc. They are characterized by high effectiveness, compactness (high surface area density), low weight and moderate cost [1].

A fluid is substance that deforms continuously when subjected to a shear stress, no matter how small that shear stress may be. A shear force is the force component tangent to a surface, and this force divided by the area of the surface is the average shear stress over the area. Shear stress at a point is the limiting value of shear force to area as the area is reduced to the point. In Fig (1.1); The fluid in the area a,b,c,d flows to the new position $a'b'c'd'$, each fluid particle moving parallel to the plate and the velocity u varying uniformly from zero at the stationary plate to U at the upper plate.

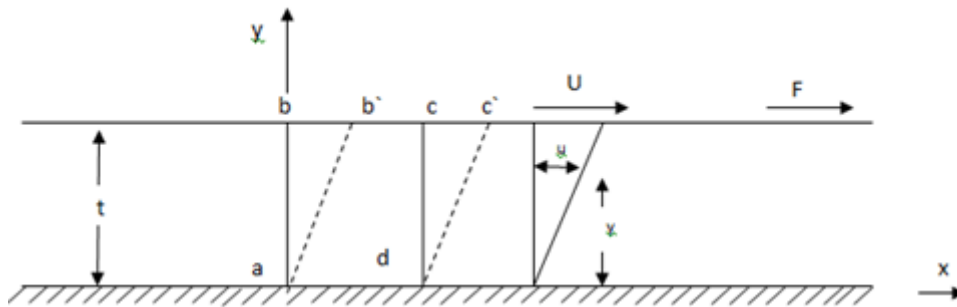

Figure 1.1 Deformation resulting from application of constant shear force.

Experiments show that other quantities being held constant, F is directly proportional to A and to U and is inversely proportional to thickness t . in equation 1.1

$$F = \mu \frac{AU}{t} \quad (1.1)$$

In which μ is the proportionality factor and includes the effect of the particular fluid [2]. If $\tau = F/A$ for the shear stress is;

$$\tau = \mu \frac{U}{t} \quad (1.2)$$



The ration U/t is the angular velocity of line ab , or it is the rate of angular deformation of the fluid, the angular velocity may also be written as $\frac{du}{dy}$, as both U/t and $\frac{du}{dy}$ express the velocity change divided by the distance over which the change occurs. However, $\frac{du}{dy}$ is more general as it holds for situations in which the angular velocity and shear stress change y . the velocity gradient $\frac{du}{dy}$ may also be visualized as the rate at which one layer moves relative to an adjacent layer. In differential form is the relation between shear stress and rate of angular deformation for one –dimensional flow of a fluid

$$\tau = \mu \frac{du}{dy} \quad (1.3)$$

The proportionality factor μ is called the viscosity of the fluid, and Eq. (1.3) is Newton's law of viscosity.

1.1.1 Mean velocity.

Liquid or gas flow through pipes or duct is commonly used in heating and cooling application, and fluid distribution network. The fluid in such application is usually forced to flow by a fan or pump through a flow section. We pay particular attention to friction, which is directly related to the pressure drop and head loss during flow through pipes and ducts. The pressure drop is then used to determine the pumping power requirement. A typical piping system involves pipes of different diameters connected to each other by various fitting or elbows to direct the fluid, valves to control the flow rate, and pumps to pressurize the fluid. The terms pipe, duct, and conduit are usually used interchangeably for flow section. In general, flow section of circular cross section are referred to as pipes (especially when the fluid is a liquid), and flow section of noncircular cross section as duct (especially when the fluid is a gas). Small diameter pipes are usually referred to as tubes. The fluid velocity in a pipe changes from zero at the surface because of the no slip condition to a maximum at the pipe center. In fluid flow, it is convenient to work with an average or mean velocity V_m which remains constant in incompressible flow when the cross section area of the pipe is constant (Fig. 1.2). The mean velocity in heating and cooling applications may change somewhat because of change in density with temperature [3].

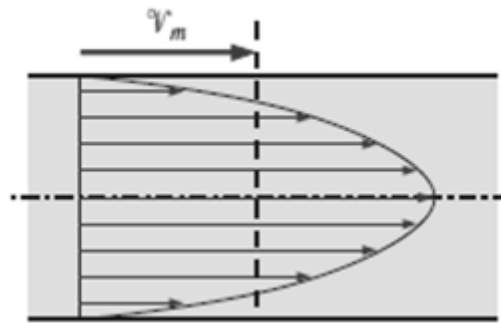

Figure 1.2 V_m mean velocity [3].

But in practice constant. Also the friction between the fluid layers in a pipe does cause a slight rise in fluid temperature as a result of the mechanical energy being converted to sensible thermal energy. The primary consequence of friction in fluid flow is pressure drop and thus any significant temperature change in the fluid duct to heat transfer. The value of the mean velocity V_m is determined from the requirement that the conservation of principle be satisfied, that is,

$$\dot{m} = \rho V_m A_c \quad (1.4)$$

Then the mean velocity for incompressible flow in a circular pipe of radius R can be expressed as:

$$\int_0^R u(r, x) r dr \quad (1.5)$$

$$V_m = \frac{2}{R^2}$$

Where \dot{m} is the mass flow rate, ρ is the density, A_c is the cross section area and $u(r, x)$ is the velocity profile [2].

Therefore, when we know the mass flow rate or the velocity profile, the mean velocity can be determined easily.

1.1.2 Reynolds Number

We can verify the existence of these laminar, transitional, and turbulent flow regimes by injecting some dye streaks into the flow in a glass pipe. The transition from laminar to turbulent flow depends on the geometry, surface roughness, flow velocity, surface temperature, and type of fluid, among other things. After exhaustive experiments in the 188s, Osborne Reynolds discovered that flow regime depends mainly on the ratio of the inertial force to viscous in the fluid. This ration is called the Reynolds number and is expressed for internal flow in a circular pipe.



$$Re = \frac{\text{inertial force}}{\text{viscous force}} \quad (1.6)$$

$$Re = \frac{LV_m}{\gamma}$$

L= characteristic length of the geometry (D -diameter in circular pipe).

$$Re = \frac{\rho DV_m}{\mu}$$

At large Reynolds number the inertial force, which are proportional to the fluid density and the square of the fluid velocity, are large relative to the viscous force, and thus the viscous force cannot prevent the random and rapid fluctuation of the fluid at small Reynolds number, however the viscous forces are large enough to overcome the inertial force and to keep the fluid in line thus the flow is turbulent in the first case and laminar in second .the Reynolds number at which the flow becomes turbulent is called the Critical Reynolds number Re_{cr} . The value of the critical Reynolds number is different for different geometries and flow condition. For internal flow in a circular pipe, and generally accepted value of the critical Reynolds number is $Re = 2300$ [4]. For flow through noncircular pipes, the Reynolds number is based on the hydraulic diameter D_h defined:

Hydraulic diameter $D_h = \frac{4 A_c}{p}$

The hydraulic diameter is defined such that it reduces to ordinary diameter D for circular pipes.

Circular pipes $D_h = \frac{4 A_c}{P} = \frac{4 (\pi D^2/4)}{\pi D} = D \quad (1.7)$

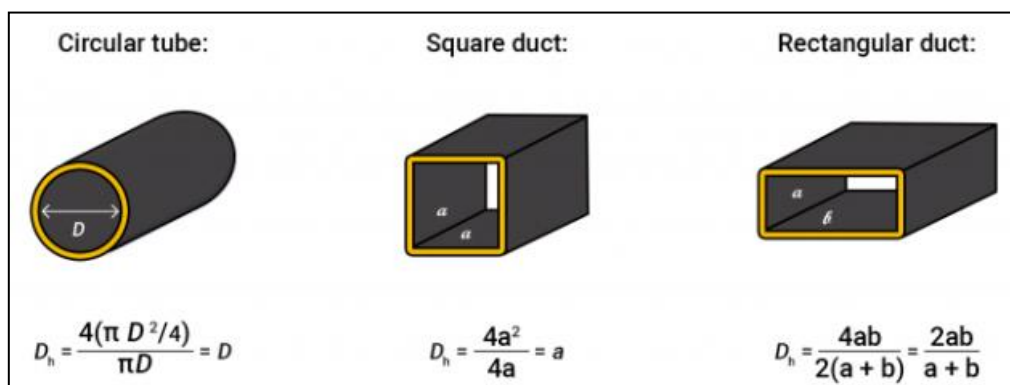

Figure 1.3 the hydraulic diameters (D_h) at different shapes [5]



It certainly is desirable to have precise value of Reynolds number for laminar, transitional, and turbulent flow, but this is not the case in practice. This is because the transition from laminar to turbulent flow also depends on the degree of disturbance of the flow by surface roughness, pipe vibrations, and fluctuations in the flow. Under most practical conditions, the flow of liquid phase in a circular pipe is laminar for $Re < 2300$, turbulent for $Re > 4000$, and transitional in between; that is;

$Re < 2300$ *laminar flow*

$Re \leq 4000$ *transitional flow* $2300 \leq$

$Re > 4000$ *turbulent flow*

In transitional flow, the flow switches between laminar and turbulent randomly. In such carefully controlled experiments, laminar flow has been maintained at Reynolds of up to 100,000 for flows approximated as in viscid flow. The Reynolds number infinity since the viscosity is assumed to be zero.

2.1 Objective

The rapid growth in high speed multi-functional miniaturized electronics demands more stringent thermal management. The present work experimentally investigates the use of staggered array of fins to enhance the rate of heat transfer while subject to a horizontal flow. In particular, the number of horizontal position and the vertical on each water flow rates are studied. Pressure drop with array of fin is examined at horizontal position. However, further work done to study the effects of hydraulic diameter (D_h) to the rectangular fin heat transfer performance.

The aim of the present study is to show that it is possible to record the change on a heat transfer performance fin inside the water system of plate finned-tube heat exchangers. Force convection investigate with different types of fluids (laminar, transition and turbulent) .To the plate finned-tube heat exchangers, in-line and staggered tube arrangements, were tested under various duct velocities. In addition, the heat performance of fins will determine for this water system for both types of direction.

3.1 Scope of the present work

Design and fabrication of the test apparatus for examine the tree types of fluids of water through the plate with array of rectangular fin heat transfer rate. To determine the thermal fin performance parameters like overall heat transfer coefficient, effectiveness and overall heat transfer of plate fin heat exchanger through hot testing under water forced flow condition. After that; study the effect of the force convection condition to performance of rectangular fin with



different plate direction. The type of relation of Re no. with Nu no. for force convection was investigated. Then the pressure drops for different types of flow at different direction of rectangular fin used was measured. The type of relation of Re no. with pressure drop (ΔP) for force convection by water media was investigated, the heat transfer coefficient was measured for all of types of fluid with array consist of ten fins to the volumetric flow rate. The range of heat transfer coefficient (h), the range of effectiveness' found, and the range of efficiency found was measured, finally the type of relation between hydraulic duct diameters' with fin heat transfer performance was calculated.

4.1 Literature Survey

Over the past few decades a large amount of study has been conducted to analyze the heat transfer and pressure drop characteristics of compact heat exchangers. Although various types of interrupted fin surfaces have been performed in the past, this study focuses on the offset-strip fin (OSF) type compact heat exchanger. Various similar studies about this type of fin are available in the literature and they will be summarized in this chapter [6-36].

Optimization of fin arrays has been studied a lot under the assumption of isothermal fins. Bejan and Morega maximized the heat transfer rate of an isothermal fin array with laminar flow when the pressure drop and total fin array width were fixed. Bejan and Morega solved the corresponding turbulent case [36]. Later, Mereu et al. minimized the thermal resistance with fixed width and fan power, but only a numerical solution was given with constant heat flux at the fins [38]. The analytical solution for this problem with isothermal fins was given by Canhoto and Heitor Reis who also included the effect of the local pressure losses [39]. Lindstedt and Karvinen extended and summarized the above studies by minimizing thermal resistance with either fixed width or fixed volume and either fixed pressure drop or fan power. More accurate solutions for the local pressure losses were used [40]. In order to take into account the decrease in the fin temperature, at least one-dimensional heat conduction must be assumed in the fins. Liu and Garimella [41] and Song *et al.* [42] have used conjugated fin array models in the optimization. Lindstedt and Karvinen [43] present optimization results which use the 2D solution of Lindstedt. For the fins; Thermal resistance was minimized with the volume, the number of the fins and either the fan power or the pressure drop fixed. Isothermal and is flux boundary conditions at the fin base were dealt with. Optimization with comparable or even more accurate conjugated heat transfer modeling has only been made in CFD studies, such as those by Li and Peterson [44] and Wang et al., [45] among others.



There is very little useful information on the optimization of non-isothermal fin arrays. Very often the optimization results are presented as tabulated values for different designs or as curves representing the effect of a design variable on the thermal resistance or the total heat transfer rate. Such results do not provide any generally applicable information and thus are not useful when either certain initial values, or the coolant, are changed [46].

Both laminar and turbulent cases are solved for gases with Prandtl number 0.7 assuming a constant temperature at the fin base, i.e. the base plate is isothermal. None of the fin or channel dimensions are fixed. The solutions of the problems are presented using non-dimensional variables, thus they are valid for fin arrays of any size.

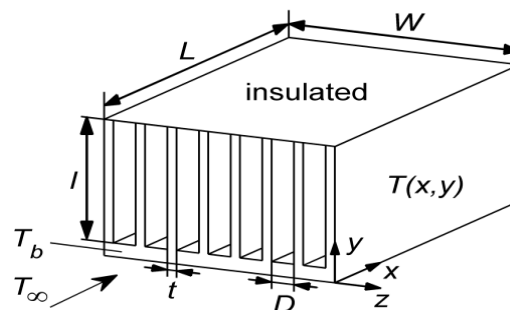

Figure 1.5 Schematic of typical heat sink used in power electronics cooling. The base plate is at the temperature. There are channels and fins [47].

Recently at 2012, Hamid Nabati [48], Mishra *et.al*; [49] and Shivdas *et. al.*; [50] used very modern numerical programs for analysis the effect of types of fluids to the fin heat transfer performance for comment shape (rectangular) for natural and force convection to the airflow system.

5.1 Experimental work

In order to experimentally measure the thermal performance of the finned heat sink, it is essential that the rate of heat transfer between the heat sink and the flowing water be accurately measured at horizontal. For the present experimental studies of heat sink performance, electrical patch heaters were used to heat the fin base.



Figure 1.6 water system to examine the performance of heat transfer setup.

It would be highly desirable to be able to indirectly obtain an accurate measurement of the rate of heat transfer from the heat sink to the flowing of water, by simply measuring the temperature to the patch heaters. In order to experimentally measure the thermal performance of the finned heat sink, it is essential that the rate of heat transfer between the heat sink and the flowing of water be accurately measured. For the present experimental studies of heat sink performance, the rmocouple type (K) was used to heat the fin base. It would be highly desirable to be able to indirectly obtain an accurate measurement of the rate of heat transfer from the heat sink to the flowing of water. Equating these two energy rates assumes a negligible heat loss off the back-side and edges of the patch heater assembly, these two energy rates assumes a negligible heat loss off the back-side and edges of the patch heater assembly.

6.1 Description of tools.

To approach the investigation of performance to array of rectangular pin fin by forced convection, we used the following devise as listed below:

6.1.1 The fins.

Geometrical parameters of rectangular aluminum fins with code name (S.I.R RFH 1100.50R 191*915900 0528) at thermal conductivity equal to $335 \text{ w/m} \cdot \text{k}$. There are 12 fins fixed at rectangular aluminum base with electrical heater with heat supply up to 1250 w.

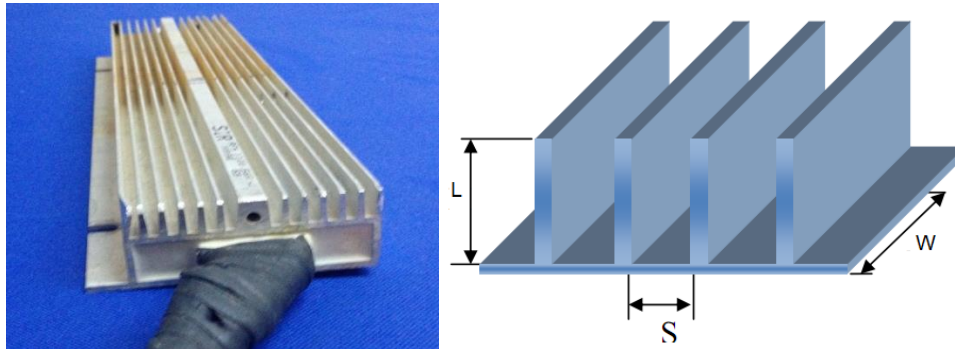

Figure 6.1(a) rectangular fins, (b) rectangular fin array.

Table 6.1 Fins properties

Geometrical Parameters	Dimensions (mm)
Fin length (w_f)	320
Fin Height (L_F)	10
Fin thickness (t)	1
Fin size (s)	5
Channel length (L_c)	10.5
Fin Parameter (P)	642

6.1.2 Flow meters

Geometrical parameters of flow meter type magnetic with code name (KROHNE CE DW 182/RR/A/K₁ 628859.10.02 PN40DN50A 182F3161 501287) is used for measuring the volumetric flow rate of water.



Figure 6.2 Magnetic meter



Table 6.2 Flow meter specification

Geometrical parameters	Dimensions
Flow meter length	(30)cm
Inlet diameter	(1.5)in
Outlet diameter	(1.5)in
measurement scale	(1200/10000) L/h
flow meter weight	(35)kg

6.1.3 Pumps

Two types of pumps used in our experimental work as shown in figures (3.3 and 3.4)for flow the water to the system cycle up to 7000 lit\hr. Geometrical parameter of pump with code name type (SAER CE) made in ITALY (Serial number(2560468 Year D)).



Figure 6.3 water pump no. 1

Table 6.3 Pump no. 1 specification

Geometrical	dimensional
Voltage	230V
Current	10.6A
r.p.m	2850 r/min
Hours Power	2.2 HP
Volume of rate	1.2-7.2 m ³ /h
High	32-50 m
High max	52m
Temperature	70 °C



Geometrical parameter of pump with code name type (POMAX QB-80 Serial number 1210160806) is used to reach the big volumetric flow rate of water.



Figure 6.4 Water pump No. 2.

Table 6.4 Specification of pump no. 2.

Geometrical	Dimensional
Voltage	220V
Current	3.8A
High max.	50m
Volume of rate	50 L/h
Size	1*1
Suck	9m
Hours power	1 hp
r.p.m	2850 L/min

6.1.4 Pipes

Pipes are made of P-Brawn pipes geode name (1N 150 1587-2GEM) has a length 4.5m , inside diameter 21mm, 32mm outside diameter.

6.1.5 Rectangular duct.

Rectangular duct made of galvanized iron and Geometrical parameter of rectangular duct is use to examine the effects of water flow rate to the fin heat transfer performance for two positions to the array of fins.

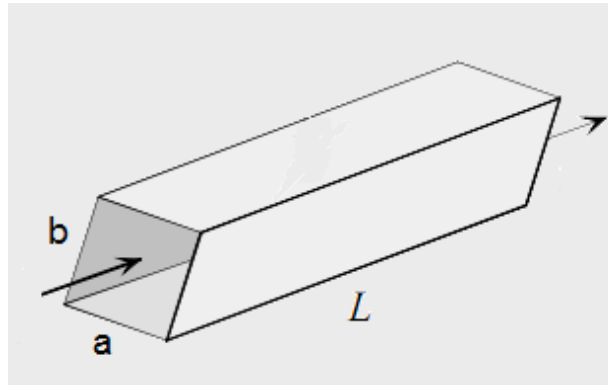

Figure 6.5 Schematic diagram of the duct

Table 6.5 Duct dimensional

Geometrical	dimensional
Volume of duct	0.4*0.2*1.5 m
Thickness	1.5mm
Length of duct	1.5m
High of duct	40cm
Width of duct	20cm

6.1.6 Gauges box

Gauges box made of galvanized iron dimensional (15*15*40) cm contain a reading gauges and main fuse, electrical wires and thermocouple connected to copper pipes fixed on fin aluminum base.

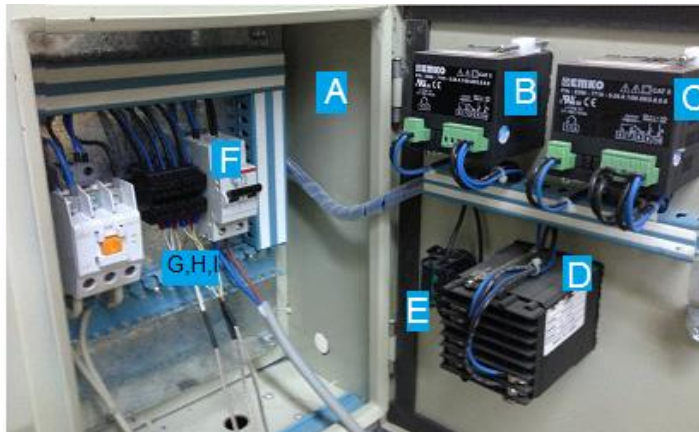

Figure 6.6 The Gauges Box

Gauge description (B,C,D)

They are three gauges, the first gauge end connected to electrical current, the other connected to thermocouple fixed on base of the fin, gives reading of base temperature (T_b) the second gauge end connected to electrical current and its fixed on the fin that gives temperature reading of the fins at the required



temperature, its surface temperature of the fins (T_F), third gauges the end connected to electrical current, the other connected to thermocouple fixed in water, each gauge with (thermostat) to control the required temperature.

Thermocouple (G,H,I)

Thermocouple is a device consist thermal wire to measure the temperature of fin base fixed on it, the fin surface and water, its other end connected to digital gauge. its type (J) to measure temperatures and type K to measure temperature of the water.

(E,F) manual breaker

It is manual breaker to control the electricity entering the device at operation to warn the device, it's very sensitive breaker to disconnect electrical current if there is a problem inside the device.

Hand valve

Manual valve is used to control the flow of water (input, output). It is used a three hand valves in this system.

Table 6.6 Hand valve specification

Model	NAME	Tube dia. in	MASS g
HV-12.01	SANWA	1 1/2	45
HV- 17-00	SANWA	1	33
HV – 8-01	TIGRE	2	55

7.1 The experimental setup and procedure

The results of experimental work consist of the four parts respectively. The first part of experimental consists of the following steps:

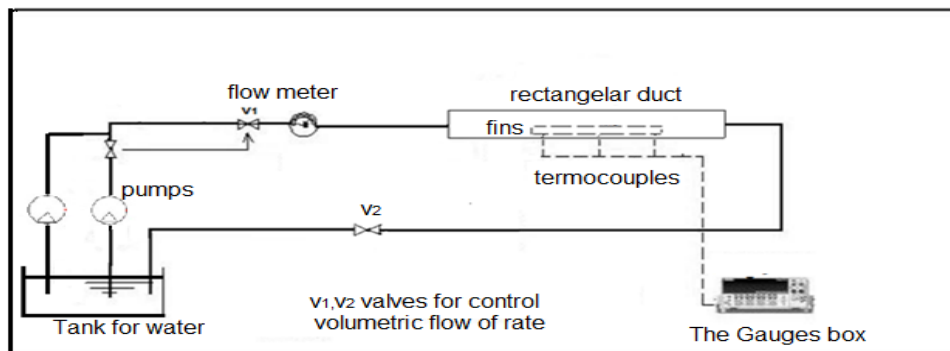

Figure 7.1 schematic view of experimental setup



1. Connecting the electric wire of operating the control box of the system with the source of the electric current.
2. Filling the cistern with fresh water.
3. We fix the fins inside the duct a horizontal shape.
4. Fixing the control meter with the temperature of the heater at 30°C. Then, operating the pump no.(1) to flow water from the cistern to the duct in order to pass on the fins inside it of a distance of 1,500m from the switching point to the duct as the fins fixed in a systematic way.
5. Fixing the controlling valve of water flow at 1200 L/h as fixing the level inside the duct through closing the exits valve at the bottom of the duct.
6. When the temperature of the base reaches 30°C disconnect the control valve automatically so that the temperature of the base will be increased up to 37°C and decreased to 30°C. As soon as the temperature become fixed at 30°C. Then, we start recording the reading from the surface of the fins through the thermocouple and the temperature of the water.
7. The same steps one repeated for the temperature with an increase of 4°C for each stage until 62°C recording the readings and writhing then claim in the table.
8. The speed of water flow is fixed by the control valve at the speed of 200 L/h and we follow the same step of the experiment from 1-to-5.
9. The speed of water flow is fixed by the control valve at the speeds of (3000,4000,5000,6000,7000)L/h at this stage. the pumps No. 1 and 2 are operated until reaching the speeds mentioned before. Then, the readings of the water and the fins are recorded separately following the previous steps from 1 to 5.

Second part of the experiment consists of the following steps:

We change the direction of fins at the vertical position inside the duct at a distance of 1.5m from water flow and we repeat the same above steps of the experiment for the same temperature and measure the temperature at the surface of the fins and measure the temperature of the water and record the readings on the table.

The third part of the experiment consists of the following steps:

1. We fix the fins at a horizontal shape after a distance of 0.75m from point of water flow at a speed of 2500L/h in order to cover the fins completely with water. Then, we fix the measuring meter of the temperature of 90°C when we reach this point; the operating switch was disconnected automatically through the thermocouple. Hence, the temperature is increased 7°C



approximately and decreases until reaching the steady point at 30°C. The temperature was recorded at the surface of the fins and water through the thermocouple.

2. We increase the water level inside the duct at the same speed 2500 L/h and we fix the temperature at 34°C. After the steady state was reached, the readings at the surface of the fins and water were recorded on the tables.
3. We follow the same steps by increasing the level of water and changing the temperature by adding 4°C for each stag until we reach 62°C. Then, record the readings at each step on the table.

8.1 Results and Discussions

The array of rectangular fins in the water duct at horizontal direction examine for different volumetric flow rate and different hydraulic diameter (D_h) to the range of water temperatures from 20 to 25 °C. The results of different hydraulic diameter (D_h) of water phase to roughness galvanized iron illustrated in the Figures 8.1, 8.2 and 8.3 at constant volumetric flow rate (1000 lit\hr.); but, the results of different volumetric flow rate from 333 to 1945 cm^3/sec at constant hydraulic diameter (D_h) equal to (28.6 cm) are shown in figures 5.16 to 5.23. a math lab program was used for calculation and drawn Figures 8.1 to 8.11.

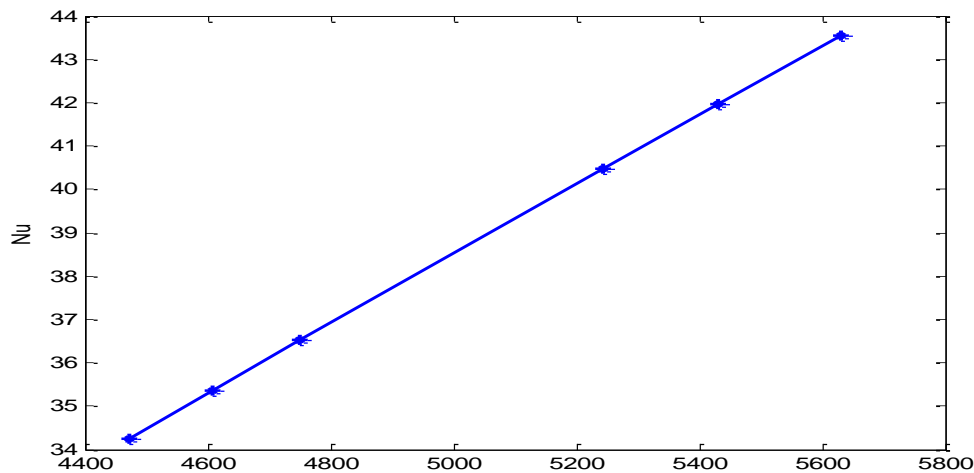

Figure 8.1 Illustrated the relation of Re no. with Nu no. at horizontal direction for variable hydraulic diameter (D_h)

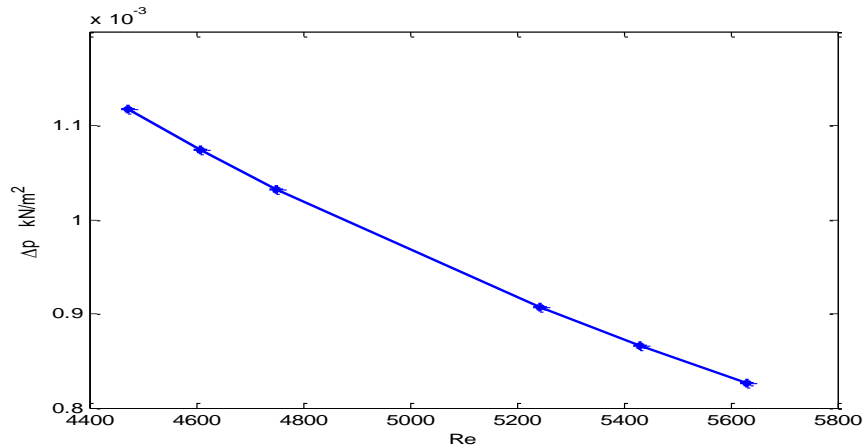

Figure 8.2 Illustrated the relation of Re no. with pressure drop (ΔP) at horizontal direction with variable hydraulic diameter (D_h)

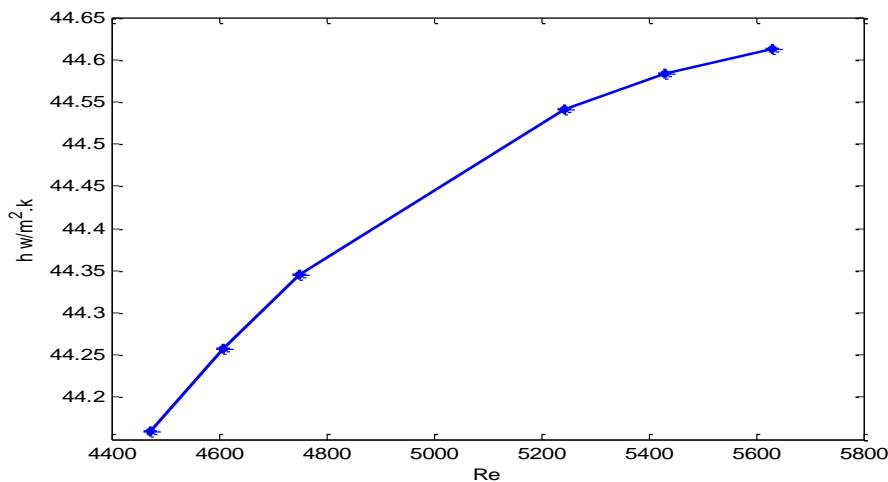

Figure 8.3 Observed the relation of Re no. with heat transfer coefficients (h) at horizontal direction with variable hydraulic diameter (D_h)

A linear relation found between the Re no. with Nu no. for horizontal direction similar to the vertical direction as shown in figure 5.11. We have a turbulent flow at horizontal direction of array of rectangular fins ,because the Re no. increase than 4000 as shown in figures 5.11 and 5.12. For turbulent water flow the pressure drop decrease and the heat transfer coefficients increase with increasing the Re no. at horizontal direction, see figures 5.11 and 5.12.

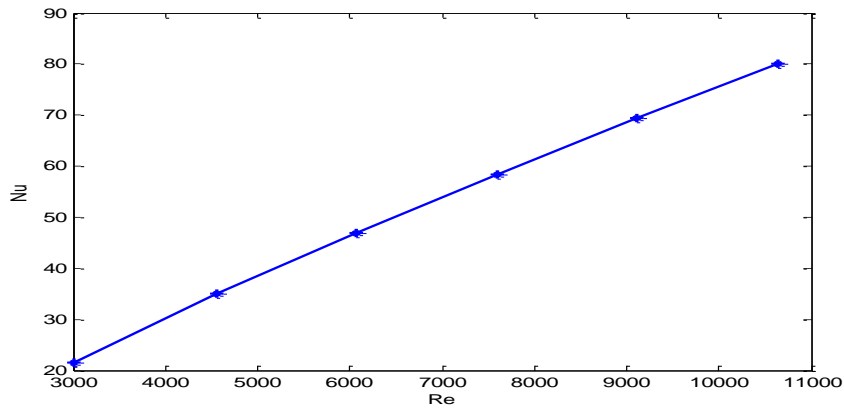

Figure 8.4 Observed the relation of Re no. with Nu no. at horizontal direction with constant hydraulic diameter (D_h)

The relation of (Re no.) with (Nu no.) for different volumetric flow rate and constant hydraulic diameter (D_h) is linear as illustrated in figure 5.16, for the range of flow rate from 333 to 1945 cm^3/sec . A linear relation obtained between the volumetric flow rate (Q) and the heat transfer coefficients (h) as shown in figure 5.17. The pressure drop increase with increasing the heat transfer coefficient for horizontal direction of array of rectangular fins as observed in figure 5.18. But the friction factor decrease with increasing the Re no. for this position as shown in figure 5.19 at constant hydraulic diameter (D_h)

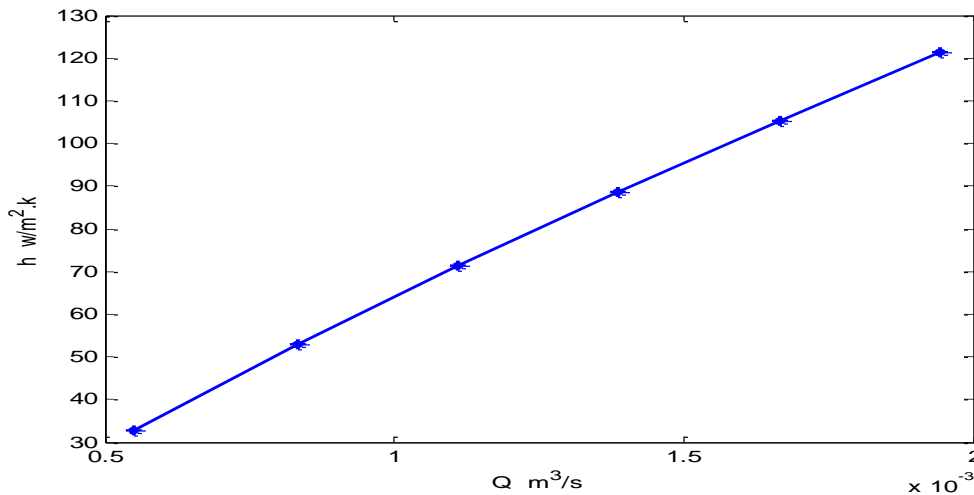

Figure 8.5 Observed the relation of volumetric flow rate (Q) with heat transfer coefficients (h) at horizontal direction with constant hydraulic diameter (D_h)

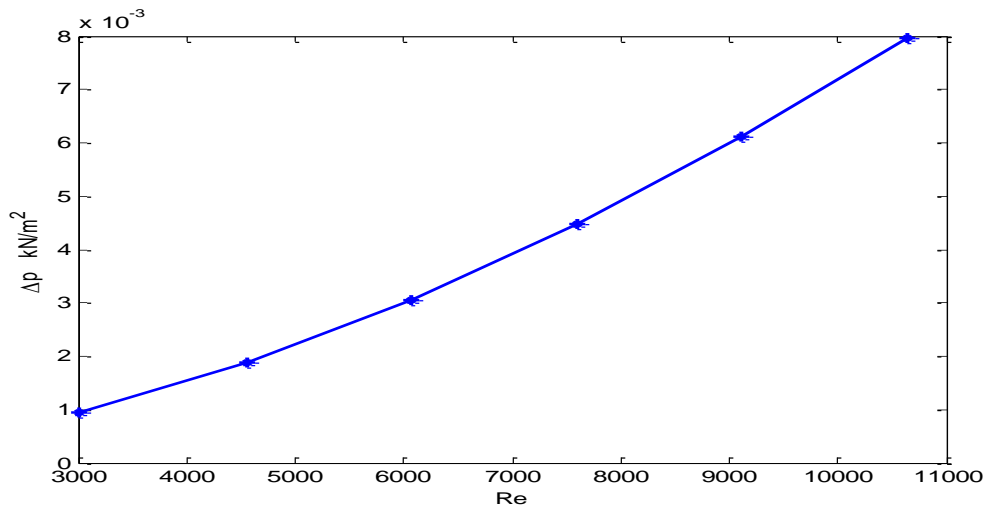

Figure 8.6. Observed the relation of Re no. with pressure drop (ΔP) at horizontal direction with constant hydraulic diameter (D_h)

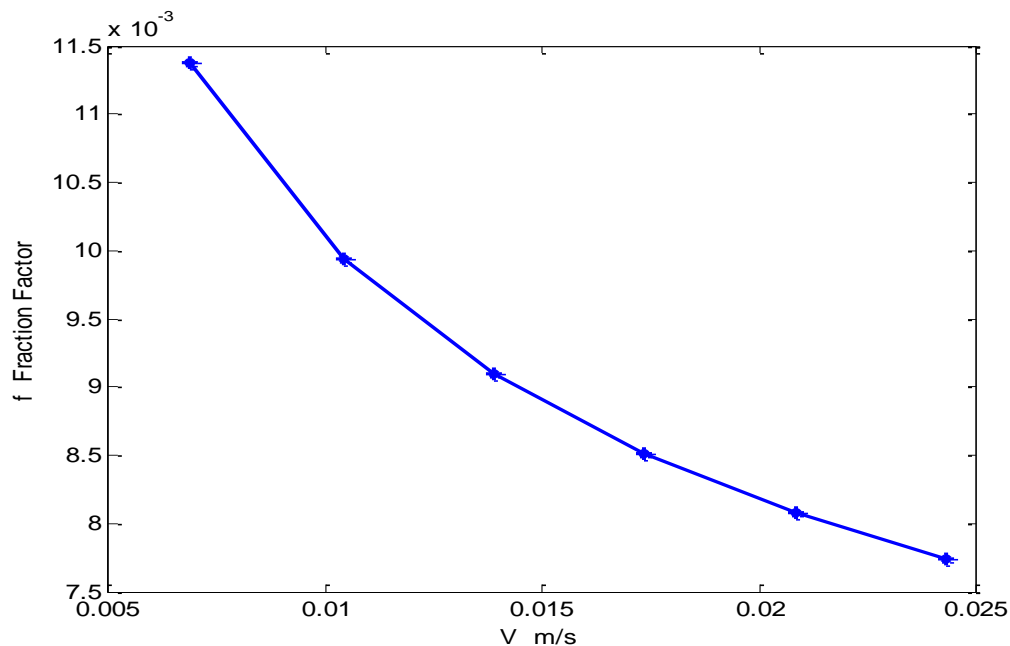

Figure 8.6 Illustrated the relation of water velocity (V) with friction factor (f) at horizontal direction with constant hydraulic diameter (D_h)

At 0.0075 m/s velocity, the friction factor (f) has a big value about **0.0113** when the fin horizontal setting is fixed. When the velocity is increased to 0.015 m/s under similar condition, the increase in this factor is about 14 percent. Further, when the velocity is increased to 0.025 m/s, the increase in friction coefficient value is about 50 percent, which is a significant increase.

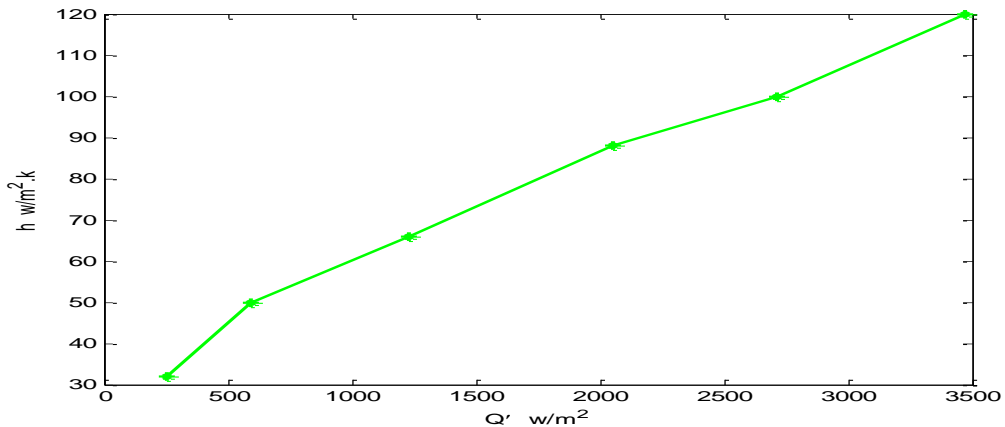

Figure 8.7 Observed the relation of heat flux (Q') with heat transfer coefficients (h) at horizontal direction at constant hydraulic diameter (D_h)

The heat flux of horizontal direction increase with increasing heat transfer coefficients at different volumetric flow rate for horizontal direction of array of fins as shown in figure 5.20.

The heat transfer ratio ($Q_{fin} \setminus Q_{water}$) with (ml) is represented in figure 5.21 as a linear relation. The performance of horizontal direction the array of rectangular fins measured by efficiency and effectiveness of these fins. This is illustrated in figure 5.22. The range of efficiency of rectangular fins is from 96 to 99 % and the effectiveness of fins has a range from 19.7 to 20.8 is to height, because the heat supply is very low 550w with enough number of fins (12 fins).

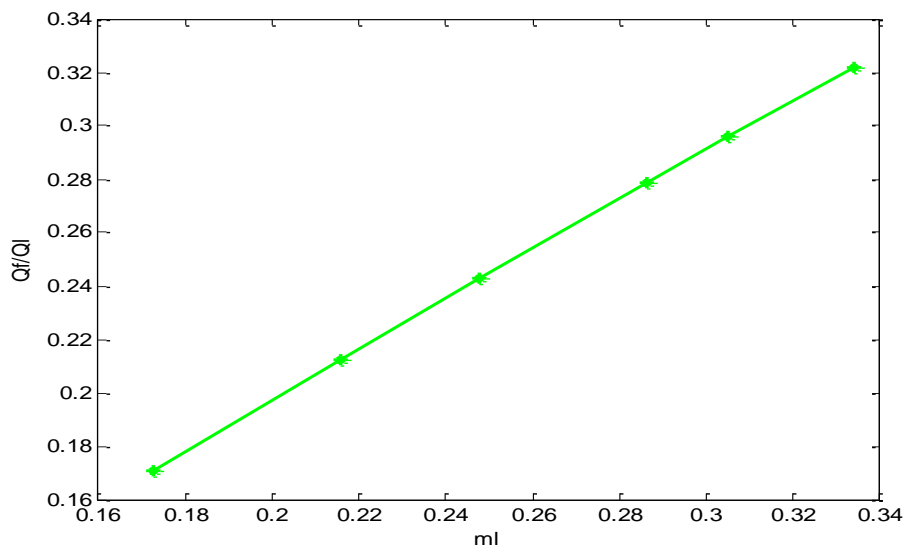

Figure 8.8 Observed the relation of heat transfer ratio with (ml) at horizontal direction with constant hydraulic diameter (D_h)

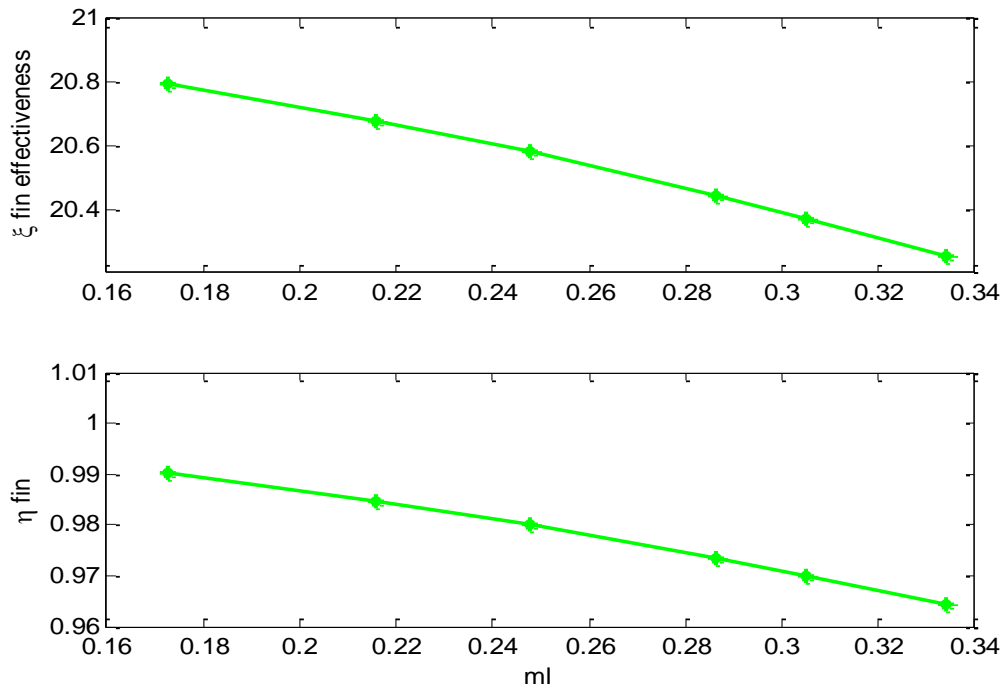

Figure 8.9 Illustrated the relation between the fin heat transfer performance (efficiency and effectiveness) at horizontal direction , with constant hydraulic diameter (Dh)

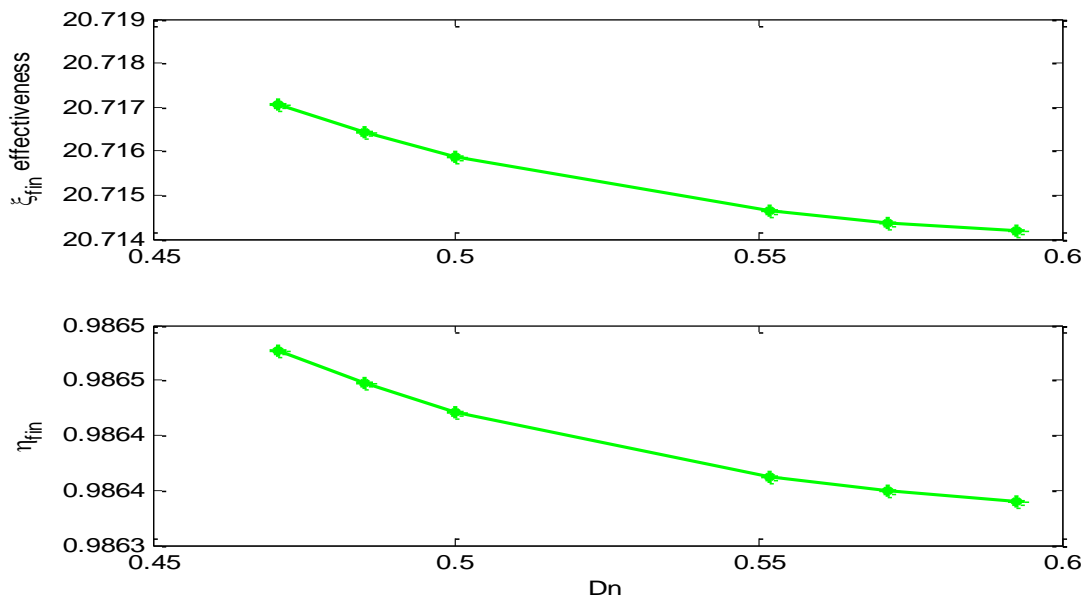

Figure 8.10 Performance of heat transfer to the arrays of fins at different hydraulic diameter (Dh)

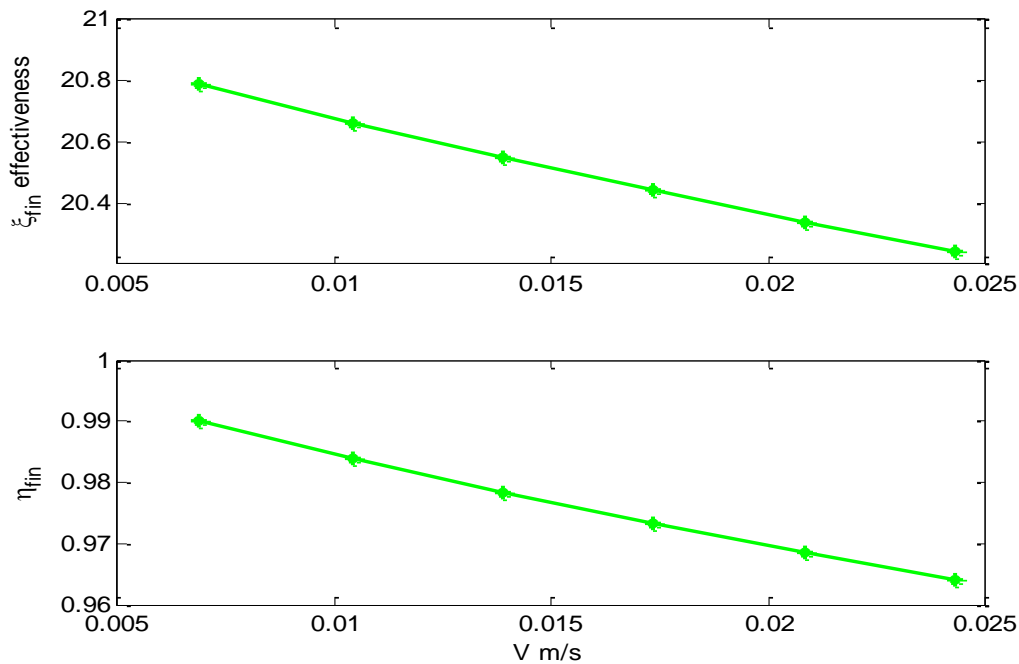

Figure 8.11 Performance of heat transfer to the arrays of fins at different water velocity

The performance of arrays of aluminum fins decrease at horizontal direction with increasing the hydraulic diameter and the water velocity as shown in the above Figures 8.1 to 8.11 (math lab program was used for calculation and drawn the above Figures 8.1 to 8.11). The efficiency of this position is very big reach to 99% mean excellent cooling done by the built cooling system.

Conclusions

From the present experimental work the following conclusions are drawn:

- Lower Reynolds number gives better values for the criteria but there is a local optimum just after the transition to turbulence.
- After considerable experimental investigation, it was concluded that the power supply and fin heat transfer (P - Q) difference was primarily due to a heat loss through the galvanized iron duct enclosure and connecting water ducts.
- The heat transfer coefficient in the fins channel increases with increasing Reynolds number as in duct flow. As expected, high pressure drop is also observed.
- The computational results by math lab programs shows that a confirmation from experiments for all range of Reynolds number.



- Forced convection over pin fin heat sinks is a very effective heat transfer mode. In many cases, the primary cause for the rise in wall temperature is the increase of the fluid temperature as it flows through the heat sink.
- To suppress the convective thermal resistance at high Reynolds number dense pin fin configurations are preferable, while for low Reynolds numbers more sparse arrangements are advisable.
- Very high heat fluxes can be dissipated at low wall temperature rise using a micro scale pin fin heat sink.
- The heat transfer and pressure drop correlations are currently not sufficiently developed, but the results strongly suggest that pin fin heat sinks deserve adequate research attention. Furthermore, pin fin configurations provide considerably more design flexibility in the geometrical selection of the pin shapes and their position.
- No effect to the position of array of rectangular fins at the heat transfer coefficient .This is because of a small different found to the range of heat transfer coefficient between them.
- It is found the range of heat transfer coefficient from 33 to 122 w/m². K. for three types of water flow at the both position used.
- The pressure drop decrease with Re no at different hydraulic diameter (Dh) and constant volumetric flow rate, while the pressure drop increase with Re no. at constant hydraulic diameter (Dh) and different volumetric flow rate for both position.
- The pressure drop is very low has a range from 0.0008 to 0.013 kN\m² for the cooling system in this work.
- The friction factor (f) decrease with increasing the water flow velocity for both position.
- The fin heat transfer performance represent by the calculation the effectiveness and the efficiency for different parameters in present work.
- The fin heat transfer performance decrease with increasing the water volumetric flow rate at constant hydraulic diameter (Dh).
- The fin heat transfer performance decrease with increasing the hydraulic diameter (Dh).
- It's found a high performance for array of rectangular fins used.
- The range of efficiency is to high reach up to 99%. This due to an excellent cooling system used.
- The effectiveness of rectangular fin used is more than 20. This mean the ratio of the fin heat transfer rate to the heat transfer rate that would exist without the fin is very big.



- The fin heat transfer performance increase with increasing the volumetric flow rate for laminar and turbulent flow and decrease at transition flow.

Considering the above points, it is concluded from the experimental results that the performance of heat transfer rate to laminar flow is better in respect of heat transfer coefficient, fin efficiency, thermal resistance, and effectiveness when compared to those of transition and turbulent fluid.

References

- [1] Anderson John David, (1995). Computational Fluid Dynamics, The Basics with Applications. SI, McGRAW-HILL, ISBN 9780016859.
- [2] Robert. W . Fox. Alan T. McDonald (1985). Introduction to Fluid Mechanics, Third Edition. Congress Cataloging NO532-84-15282.
- [3] Victor L. Streeter E. Benjamin Wylie (1975). Fluid Mechanics', sixth Edition. McGraw-hill. ISBN 0-07-062193-4.
- [4] Cengel Yunus A., (2004). Heat Transfer- a Practical Approach. SI units 2nd Edition. Tata Mc Graw Hill Co , No.:156-168,333-352&459-500.
- [5] Stebin Samuel, (2019). HYDRAULIC DIAMETER – PURPOSE, FORMULA, ALTERNATIVES, APPLICATIONS.
- [6] Cengel Yunus A.(2003). Heat transfer:A Practical Approach, 2nd edition SI McGraw HiLL Higher Education-ISBN 0-07-245893-3.
- [7] Cengel Yunus A. and Boles Michael , (2007). Thermodynamics, An Engineering Approach. SI : McGraw HiLL International student edition-ISBN-13:978-007157718.
- [8] Incropera f.P., De witt D.P.(1996). fundamentals of heat and mass transfer. 4th Edition. john Wiley & Sons, No 147-172.
- [9] Baskaya Senol, Sivrioglu Mecit, and Ozek Murat (2000). Parametric study of natural convection heat transfer from horizontal rectangular fin arrays, Int. J. Thermal Science, 39,797-805.
- [10] kzuya Tatsumi, Shintaro Matsuzaki, Kazuyoshi Nazuyoshi Nakabe, October(2007). Notch arrangement effects on heat transfe characteristics in a channel with cut fin.
- [11] William S.Janna(2000). Engineering Heat Transfer, second Edition. CRC Press LLC, NO 0-8493-2126-3.
- [12] Sadik KaKac. Hongtan Liun (2002). Heat Exchangers Selection, Rating, and Thermal Design, second edition. CRC Press LLC, NO 0-8493-0902-6.
- [13] MILLS, A.F. (1999) Heat Transfer, second edition. prentice Hall, Inc., ISBN 0-13-947624-5.



- [14] Kau-Fui Vincent Wong (2003) Intermediate heat transfer Marcel Dekker AG ISBN 0-8247-4236-2.
- [15] Greg F. Naterer,H(2003). Heat transfer in single and Multiphase systems. CRC prees LLC.
- [16] Chowdhury , K., Sarangi , S. (1984). The effect of Variable specific Heat of the working Fluid on the Performance of counter flow Heat Exchangers . Cryogenics NO: 24 679-680.
- [17] Sane N.K.,Sane S.S., AND Parishwad G.V,January (2006) .Ntural Convection Heat Transfer Enhancement in Horizontal Rectangular fin Array with Inverted Notch, 18th National & 7th ISHMT- ASME Heat and mass transfer Conference. IIT, Guwahati,312-317.
- [18] Patankar S.V. and Prakash C. 1981. An Analysis of Plate Thickness on Laminar Flow and Heat Transfer in Interrupted Plate Passages. *International Journal of Heat and Mass Transfer* 24:1801-1810.
- [19] Sparrow, E. M., Baliga, B. R. and Patankar S. V. 1977. Heat Transfer and Fluid Flow Analysis of Interrupted – wall Channels, with Application to Heat Exchangers, *Journal of Heat Transfer* 99: 4-11 .
- [20] Kays W. M. and London A. L. 1964. *Compact Heat Exchangers*. 2nd edition, NewYork: McGraw Hill .
- [21] Joshi H.M. and Webb R.L. 1987. Heat Transfer and Friction in Offset Strip Fin Heat exchanger. *International Journal of Heat and Mass Transfer* 30(1):69-80 .
- [22] Kalkar A.K. and Patankar S.V. 1990. Numerical Prediction of Fluid Flow and Heat Transfer in a Circular Tube with Longitudinal Fins Interrupted in the Stream wise Direction. *Journal of Heat Transfer* 112:342-351.
- [23] Maughan J.R. and Incropera F.P. 1990a. Mixed Convection Heat Transfer with Longitudinal Fins in a Horizontal Parallel Plate Channel: Part I-Numerical Results. *Journal of Heat Transfer* 112:612-622.
- [24] Maughan J.R. and Incropera F.P. 1990b. Mixed Convection Heat Transfer with Longitudinal Fins in a Horizontal Parallel Plate Channel: Part II-Experimental Results. *Journal of Heat Transfer* 112:634:645.
- [25] Manglik R. M. and Bergles A. E. 1995. Heat Transfer and Pressure Drop Correlations for the Rectangular Offset Strip Fin Compact Heat Exchanger. *Experimental Thermal Fluid Science* 10:171 – 180.
- [26] Hu S and Herold K. E. 1995a. Prandtl number effect on offset fin heat exchanger performance: predictive model for heat transfer and pressure drop. *International Journal of Heat and Mass Transfer* 38(6):1043–1051.



- [27] Hu S and Herold K. E. 1995b. Prandtl number effect on offset fin heat exchanger performance: experimental results. *International Journal of Heat and Mass Transfer* 38(6):1053–1061
- [28] Zhang L.W., Balachandar S., Tafti D.K. and Najjar F.M. 1997. Heat Transfer Enhancement Mechanisms in Inline and Staggered Parallel-Plate Fin Heat exchangers. *International Journal of Heat and Mass Transfer* 40(10):2307-2325.
- [29] Harikrishna V.& Emmanuel C.(2006). Studies on force convection nanofluid flow in circular conduits. *ARNP Journal of Engineering and Applied Sciences*. ISSN 1819-6608.
- [30] Dejong N. C. and Jacobi A. M. 1997. Experimental Study of Flow and Heat Transfer in Parallel – Plate Arrays: Local, Row-by-Row and Surface Average Behavior. *International Journal of Heat Mass Transfer* 40:1365-1378.
- [31] Comini G., Croce G. and Nonino C. 2004. Modeling of Convection Enhancement Mechanisms. *International Journal of Numerical Methods for Heat and Fluid Flow*.14:66-84
- [32] Michna J. G., Jacobi A. M. and Burton L. R. 2005. Air-side Thermal – Hydraulic Performance of an Offset Strip Fin Array at Reynolds Numbers up to 120 000, Fifth *International Conference on Enhanced, Compact and Ultra – Compact Heat exchangers: Science, Engineering and Technology* 8-14
- [33] Muzychka Y. S. and Yovanovich M. M. 2001a. Modeling the f and j Characteristics of the Offset Strip Fin Array. *Enhanced Heat Transfer* 8:261-267.
- [34] Muzychka Y. S. and Yovanovich M. M. 2001b. Modeling the f and j Characteristics for Transverse Flow through an Offset Strip Fin at Low Reynolds Number. *Enhanced Heat Transfer* 8:243-259.
- [35] Guo L., Chen J., Quin F., Chen Z. and Zhang W. 2008. Empirical Correlations for Lubricant side Heat Transfer and Friction Characteristics of HPD type Steel Offset Strip Fins. *International Communications in Heat and Mass Transfer* 35: 251-262.
- [36] Guo L., Chen J., Quin F., Chen Z. and Zhou Y. 2007. Influence of Geometrical Factors and Pressing Mould Wear on Thermal-Hydraulic Characteristics for Steel Offset Strip Fins at Low Reynolds Number. *International Journal of Thermal Science* 46:1285-1296.
- [37] Bejan A and Morega M 1994 *Int. J. Heat and Mass Transfer* 37 1045-8
- [38] Mereu S, Sciubba E and Bejan A 1993 *Int. J. Heat and Mass Transfer* 36 3677-86



- [39] Canhoto P and Heitor Reis A 2011 *Int. J. Heat and Mass Transfer* 54 1441-
- [40] Lindstedt M and Karvinen R 2012 *J. Enhanced Heat Transfer* in print
- [41] Liu D and Garimella S V 2005 *Int. J. for Numerical Methods in Heat & Fluid Flow* 15 7-26
- [42] Song G-E, Lee J and Lee D-Y 2012 *Int. J. Heat and Mass Transfer* 55 2992-8
- [43] Lindstedt M and Karvinen R *Proc. 6th BHTC2011*, (Tampere, Finland, 24-26 August 2011) ISBN 978-952-15-2638-1
- [44] Li J, Peterson G P 2007 *Int. J. Heat and Mass Transfer* 50 2895-904
- [45] Wang Z-H, Wang X-D, Yan W-M, Duan Y-Y, Lee D-J and Xu J-L 2011 *Int. J. Heat and Mass Transfer* 54 2811-9.
- [46] Kays W M 1950 *Trans. ASME* 72 1067-74
- [47] Charlotte Wilhelmsson Jinliang Yuan, Bengt Sunden (2007) .Water condensation and two –phase flow modeling for a plate heat exchanger channel . Conference// ASME International Mechanical Engineering Congress and Exposition. Seattle,USA:S.N2007.
- [48] Hamid Nabati (2012).Numerical analysis of heat transfer and fluid flow in heat exchanger with emphasis on pin fin technology. Malardalen University press Dissertations no. 98.
- [49] Mishra A.K., Nawal S. and Thundil Karuppa Raj R.(2012). Heat Transfer Augmentation of Air Cooled Internal Combustion Engine Using Fins through Numerical Techniq ues. Research journal of Engineering Sciences Vol. 1(2), 32-40,ISSN 2278-9472.
- [50] Shivdas S. Kharche, Hemant S. Farkade (2012). Heat transfer analysis through fin array by using natural convection, International journal of Emerging Technology and Advanced Engineering ISSN 2250-2459.



الفهرس

الصفحة	اسم الباحث	عنوان البحث	ر.ت
1-45	سالم فرج زوبيك	الاحتباك في القرآن الكريم (دراسة بلاغية)	1
46-69	ربيعة عبد الفتاح أبو القاسم	نقص الإمكانيات التدريسية ودورها في تدني الأداء المهني للمعلم	2
70-104	مسعود عبد الغفار التويمي	المصطلحات البديعية مفهوماً وإجراءً عند ابن قرقماس (الجنس أنموذجاً)	3
105-128	فرج ميلاد عاشور	النقد وأثره في تطور البلاغة	4
129-142	E. M. Ashmila M. A. Shaktor K. I. QahwatK	Effects of composition and substrate temperature on the optical properties of CuInSe ₂ thin-film	5
143-157	رويدة عثمان رمضان البكوش	آليات تطوير وتقويم أداء الأستاذ الجامعي	6
158-175	بشير عمران أبوناخي الصادق محمود عبد الصادق	الخدمات التعليمية ببلدية الخمس (الكفاءة - الكفاية) سنة 2019م	7
176-201	فاطمة رجب محمد موسى	المقالة الذاتية (دراسة وصفية)	8
202-230	نعيمة سالم اعليجة إيمان المهدي الرمالي	فاعلية استخدام استراتيجيات سكامبر في تدريس الهندسة لتنمية القدرة علي التفكير الإبداعي والتواصل الرياضي والميل نحوها لدي تلاميذ المرحلة الإعدادية	9
218-226	حنان صالح المصروب	دراسة تأثير استبدال الرصاص في خصائص الموصلية الفائقة لـ TI- 1212 المحضر بحجم النانو	10
227-233	ربيع مصطفى ابوراوي فرج عبدالجليل المودي محمود محمد حواس فاروق مصطفى ابوراوي	تحديد درجة الحموضة وقيم كل من النفاذية والامتصاصية في بعض العينات من الزيوت النباتية المحلية والمستوردة- ليبيا	11
234-264	أمنه العربي سالم خليفه محمد حسن عبدالسلام قدوره	الضغوط المهنية وعلاقتها بدافعية الإنجاز لدي عينة من العاملين بالإدارة العامة بجامعة المرقب	12
265-291	عائشة مصطفى المقرير حنان محمد الاطرش ربيع عبدالله ابو عنيزة	اتجاهات النمو العمراني في مدينة مسلاته	13
292-307	عبدالمجيد عمر الجروشي	اتجاهات طلبة كلية التربية جامعة مصراتة نحو المرض النفسي	14
308-323	Abdul Hamid Alashhab	La femme, l'enfant et la violence familiale dans le roman marocain, le cas de : Le Passé simple de Driss Chraïbi	15



324-331	Hosam Ali Ashokri Fuad Faraj Alamari	The Inhibitory Effect of Common Thyme <i>Thymus vulgaris</i> Aqueous Extracts on Some Types of Gram-Positive and Gram-Negative Bacteria that Infect the Human Respiratory System	16
332-348	إنتصار علي ارهيمه	استخدام تحليل التباين الأحادي (لدراسة تأثير الملوحة على نبات الشعير)	17
349-363	إنتصار احمد احميد	ميناء الخمس البحري	18
364-386	فرج محمد صالح الدريع	تجار ولاية طرابلس الغرب والتغير في السلع (دراسة وثائقية في أحد مصادر تكوين الثروة) (1835-1912م)	19
387-413	حنان علي محمد خليفة	" قضية الإلهام في الشعر "	20
414-427	أحمد على معتوق الزائدي	الرجل المحرم للمرأة في الشريعة الاسلامية	21
428-447	محمد عبد السلام دخيل عبد اللطيف سعد نافع	الثقافة الاستهلاكية عند الشباب في ليبيا "دراسة ميدانية في مدينة الخمس"	22
448-471	إلهام نوري الشريف نورية محمد أبوشرنته	النظام الانتخابي في ليبيا عام 2012م	23
472-487	Salem Mohamed Edrah Afifa Milad Omeman	The Phytoconstituents Screening and Antibacterial Activities of Leaves, Seeds Bark and Essential Oil Extracted from <i>Carya illinoensis</i> Plant	24
489-505	أحمد المهدي المنصوري	النص الشعري بين التأويل والتلقي خطاب الصورة عند الرقيعي أنموذجاً	25
506-521	Ibrahim M. Haram Mohamed E. Said Ahmad M. Dabah Osamah A. Algahwaji	Energy Recovery of Ethylene Dichloride (EDC) Production by Pinch Analysis (Abu-Kamash EDC plant)	26
522-544	زهرة المهدي أبوراس هنية عبد السلام بالوص	التنمر المدرسي بين الطلاب تعريفه ، أسبابه، أنواعه ومخاطره، وطرق مواجهته وعلاجه	27
545-565	عبدالله محمد الجعكي	حذف المفعول به اقتصارا واختصارا دراسة نحوية دلالية تطبيقية في نماذج من شعر ابن سنان الخفاجي	28
567-579	Najah Mohammed Genaw Sahar Ali Aljamal	EFL Learners' Attitudes towards the Use of Vocabulary Learning Strategies	29
580-592	نور الدين سالم رحومة قريبع مسعودة رمضان علي العجل	الزمان الوجودي عند هيدجر وعبد الرحمن بدوي	30
593-600	Rajaa Mohamed Sager Saeeda Omran Furgan	Study of the relationship between the nature of wells water in Libyan southwestern zone and the occurrence of corrosion in the transferring metal pipelines	31



601-616	Sami Muftah Almerbed Abdumajid Mohamed Haddad Milad Ali Abdoalsmee	Evaluation of the Use of Technology in Private Schools	32
617-630	اسامة عبد الواحد البكوري ريم فرج بوغرارة	(جماليات الضوء في فن النحت) (دراسة تحليلية)	33
631-640	Affra A B Hemouda Silla Hiba Abdullah Ateya Abdullah	Modern Technology in Database Programming, Software Engineering in Computers	34
641-656	Ashraf M. Saeid Benzrieg Abdullah M. Hammouche Abdelbaset M. Sultan	Prediction of Chronic Kidney Diseases Using Artificial Neural Network	35
657-674	Abdu Assalam A. Algattawi Ali M Elmansuri	Radon Concentration Due To Alpha Contribution Effects Of Soil And Rock Samples In Different West And Midlibyan Regions	36
675-692	Mohamed Ali Abunnour Nuri Salem Alnaass Mabruka Abubaira	Demographic Analysis of Socioeconomic Status and Agricultural Activities in Sugh El-Chmis Alkhums 1973- 2014	37
693-704	Abdulbasit Alzubayr Abdulrahman Omar Ismael Elhasadi Zaynab Ahmed Khalleefah	Some applications of harmonic functions	38
705-729	عبدالحاميد مفتاح أبو النور حنان فرج أبو علي محمد ابو عجيله البركي	استشراف المستقبل و توظيف التطبيقات الالكترونية الذكية في تعليم تلاميذ مرحلة التعليم الاساسي	39
730-756	رجعة سعيد محمد الجنقاوي عبدالسلام ميلاد المركز	الاستهلاك المائي في منطقة الخمس ومشكلاتها والبدائل المطروحة لحلها	40
757-773	سيف بن سليمان بن سيف المنجي سماح حاتم المكي محمد رازمي بن حسين	التعلم عن بعد في حالات الطوارئ: تطبيقات التدريس وتجربة التعليم بمدارس التعليم ما بعد الأساسي في سلطنة عُمان	41
774-780	Aisha ALfituri Benjuma Najmah ALhamrouni Ahmed	Estimation of lead (II) concentration in soil contaminated with sewage water of Alkhums city	42
781-786	Hanan Saleh Abosdil Rabia Omar Eshkourfu Atega Said Aljenkawi Aisha Alfituri Benjuma	Determination of Calcium in Calcium Supplements by EDTA Titration	43
787-805	ميسون خيرى عفيفة ابوبكر محمد محمد عيسى	مستوي القلق وعلاقته بالغبرة عن الذات	44



806-842	عثمان علي أميمن سليمة رمضان الكوت فاطمة نوري هويدي	مظاهر عدم الاهتمام بالعمل الأكاديمي والتجاوز عن الغش والسلوك الفعلي للغش وعلاقتها بالأنوميا: دراسة إمبريقية على عينة من طلبة جامعة المرقب	45
843-878	أمل إلهام إلهام فاطمة محمد ابوراس	دور الاخصائي الاجتماعي في التعامل مع مصابي فيروس كورونا	46
879-892	مصباح أحمد بونة مسعود عبدالسلام غانم	الكشف عن الهرمونات والمضادات الحيوية باستخدام جهاز الإليزا ELISA في لحوم الدجاج في مدينة بني وليد	47
893-911	مصباح أحمد بونة مسعود عبدالسلام غانم مصباح عبدالجليل محمد	تقدير نسبة محسن الخبز (برومات البوتاسيوم) في مخابز الغرب الليبي	48
912-925	بدرية عبد السلام محمد سالم	دراسة بعض الخواص الكيميائية والفيزيائية لبعض عينات من الحليب السائل المحلي والمستورد في السوق الليبي - الخمس	49
926-941	Kamal Tawer Abdusalam Yahya Munayr Mohammed Amir	Cloud Computing Security Issues and Solutions	50
942-972	عائشة عمار عمران ارحيم	فاعلية استخدام برنامج كورت في تدريس مادة الجغرافيا لتنمية مهارات التفكير التأملية لدى طلاب المرحلة الإعدادية	51
973-999	Mohsen Faroun Ahmed Assma Musbah Said	The Use of Staggered Array of Aluminum Fins to Enhance the Rate of Heat Transfer While Subject To a Horizontal Flow	52
1000-1021	فاطمة محمد ارفيدة	وسائل التواصل الاجتماعي وعلاقتها بظاهرة الاغتراب الاجتماعي دراسة ميدانية على عينة من الشباب داخل مدينة مصراتة	53
1022-1035	هدية سليمان هويدي رقية مصطفى فرج أبوظهر	تصميم دروس الكترونية في مادة الحاسوب للصف الأول ابتدائي تطبيق داعم للمنهج الدراسي في ليبيا	54
1036-1048	نجاه صالح اليسير	علم اللغة التطبيقي (النشأة- المفهوم- المجالات- المصادر- الخصائص- الفروع)	55
1049-1061	محمد سالم مفتاح كعبار سالم رمضان الحويج	تحقيق متطلبات الجودة وتحليل المخاطر ونقاط الضبط الحرجة الهاسب (Haccp) في صناعة الأسماك (بالتطبيق على الشركة الليبية لصناعة وتعليب الأسماك الخمس الفترة 12- 2015م إلى 1-2016م)	56
1062-1075	إبراهيم رمضان هدية مصطفى بشير محمد رمضان	نسقية التشبيه عند ميثم البحراني	57
1076-1094	سعد الشيباني الجدير	مفهوم الزمان والمكان والعوامل المؤثرة في تصوير ما بعد الحداثة	58
1095		الفهرس	